

<< www.profibus.com
<< www.profinet.com

PI News

- P1 PROFIsafe reaches 190,000 Nodes
- P1 International Meeting at Hanover discusses Joint Strategies
- P1 Show Successes
- P1 Conference covers Pharma to Water ... and more!
- P2 ARC White Paper on PROFIsafe
- P2 Pump Profile assists Plant Management
- P2 PROFIsafe on PROFIBUS and PROFINET
- P2 Tool Calling Interface
- P2 PROFINET for Motion Control ramps up
- P2 PROFINET System Description
- P3 Fieldbus into Laboratories

PI World

- P5 China
- P5 Middle East
- P5 Netherlands
- P5 Japan
- P5 Italy
- P5 Switzerland

Applications

- P3 UK/ Waste Water
- P4 Australia/ Open Cast Mining

New Products

- P4 AS-i Gateway
- P4 IO-Link Starter Kit
- P4 Control Unit
- P4 DP-V1 Master
- P4 Copper to Fiber Converters
- P4 High Speed Wireless
- P4 Compact I/O
- P4 Demo DTM CD

PI Network

PROFIsafe REACHES 190,000 NODES

The number of PROFIsafe-enabled systems in operation around the world has passed 20,000, making PROFIsafe the leading Safety fieldbus technology by a wide margin. In terms of safety devices, this represents nearly 190,000 nodes.

PROFIsafe is the high integrity communications profile which enables PROFIBUS and PROFINET fieldbus systems to meet SIL3

requirements. It has been making rapid progress recently in all sectors of industry, including process automation. The automotive industries are one of

the main users of PROFIsafe, with drives being the fastest growing market sector. However, almost 10% of the installed base is in process automation, where PROFIsafe is

used for tasks such as stopping pumping systems and initiating shut downs. The first PROFIsafe-enabled PROFIBUS PA

instruments are expected around mid-2006, to further expand penetration in this critical sector. PROFIsafe is now being used in WLAN systems too.



SHOW SUCCESSSES

The PROFIBUS / PROFINET booths at Hannover Fair and ACHEMA were real centers of communication. New products and technology trends were presented on the booths at both fairs and PROFIBUS personnel were highly



active, giving presentations and contributing

to Forums.

The next major European show for PROFIBUS and PROFINET will be SPS/IPC/Drives in Nuremberg, in November though there are plenty of other opportunities to see PROFIBUS at other regional events - SEE below and **back page**.



CONFERENCE COVERS PHARMA TO WATER ... AND MORE

The 2-day International User Conference in UK in June will cover PROFIBUS, PROFINET and PROFIsafe, based on expert presentations designed to lead attendees through the basics of the technologies right up to their use in real world applications.

The first day includes papers covering pharmaceuticals to water, detailing end user, contractor and supplier experiences. Parallel streams of 'Primer' lectures and 'Master Classes' will see the PROFIBUS Competence Centers at Manchester Metropolitan University and PROCENTEC in the Netherlands speaking on topics such as installation practice and pitfalls, system testing and verification.

INTERNATIONAL MEETING AT HANOVER DISCUSSES JOINT STRATEGIES

Chairmen from 12 of PI's regional organisations (RPAs) came together during Hanover Fair to discuss international marketing activities for the upcoming months. Following the success of last year's press tours, further major international press work is planned for 2006 to promote PROFIBUS and PROFINET all over the world. In addition to these central activities RPA's themselves organize local roadshows, conferences, trade shows and exhibitions. Read more about RPA international activities on the back page of PROFINEWS. You'll find contact details for all 24 RPAs there too, plus first details of a new RPA in formation for the Middle East, and lots more.



Day 2 covers PROFINET and PROFIsafe in particular. Visitors can choose to attend one or both days, including a 'table-top' exhibition. The venue is Coombe Abbey in Warwickshire, UK and the dates are 27-28 June. **More information**



PI News

ARC WHITE PAPER ON PROFIsafe

ARC Advisory Group has published a White Paper called 'PROFIsafe:

Networked Safety for Process and Factory Automation' about latest trends in safety technology.

Safety has evolved from being a cost burden and a 'necessary evil', it says, into a strategy for improving productivity and reducing downtime. Running separate buses no longer fits with modern automation philosophy. The document describes how safety can now be achieved in drives and motion control applications using latest technologies, together with the operational benefits.

Part of the White Paper is dedicated to the realization of PROFIsafe on PROFIBUS and PROFINET by PI. A chapter entitled 'Networked Safety in Practice' describes case studies in USA and Sweden. One includes a wireless-application.

The White Paper can be **downloaded free of charge here.**

PUMP PROFILE ASSISTS PLANT MANAGEMENT

PI has specified a PROFIBUS/PROFINET profile for vacuum and hydraulic pumps in collaboration with the VDMA (Verband Deutscher Maschinen- und Anlagenbau - German Engineering Federation) and NAMUR (User Association for Automation in Process Industries). An implementation of the profile for both communication systems is planned for the spring of 2007.

Pumps are a key component in process automation, but commissioning and maintenance can involve excessive time and costs. Pumps can also provide valuable data for operational and asset management. The new profile will lead to specifications that span type and application on the one hand and, on the other, specify profile extensions for mapping the functionality of pump types in various application areas. Interoperability and interchangeability of pumps from different manufacturers will be ensured, leading to easy deployment of multi-vendor systems, as expressly requested by users.

PROFIsafe ON PROFIBUS AND PROFINET

This new 6-page PROFIsafe brochure explains safety-oriented automation with PROFIBUS and PROFINET. The brochure describes how PROFIsafe works and provides plenty of useful information to help make decisions about using the technology. Over 190,000 PROFIsafe devices are in use (See Page 1).

PROFIsafe benefits include:

- >> Different architectures can adopt PROFIsafe communication.
- >> TÜV-certified software allows easy implementation and cost-efficient replication of a safety solution.
- >> Existing and future standards

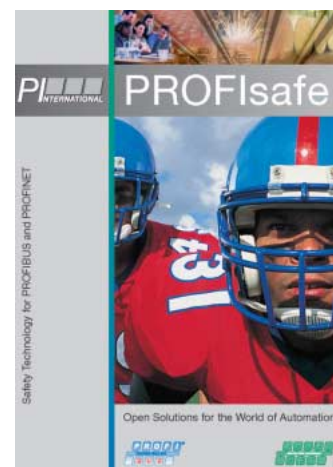

defined by PI for safety-relevant applications can be used.
>> Platform-wide safety communication is possible using the 'black channel' principle on both PROFIBUS DP/and PROFINET IO.

Download the brochure here

TOOL CALLING INTERFACE

A PI Working Group is specifying a new interface for integrating open and proprietary device operating tools. Called Tool Calling Interface, or TCI, it is implemented in the central engineering tool of an automation system (PLC, Soft PLC). Parameters are passed to the TCI in a common file structure to allow the uniform but still simple integration of existing operating

tools. This is particularly relevant for variable-speed drives and components of machine safety (e.g. with PROFIsafe) which both need efficient operating tools to fully realize customer benefits. TCI also supports open standards such as FDT and EDDL.

The PROFIBUS TCI specification is now available for review. Adoption is scheduled for September 2006. Mapping for PROFINET will follow soon after.

PROFINET SYSTEM DESCRIPTION ONLINE

You want to know what PROFINET is? Need to explain it to customers or colleagues? Then our new PROFINET System Description will help. It provides a comprehensive, easily digested, overview of PROFINET and is available **FREE! Download it here!**

PROFINET FOR MOTION CONTROL RAMPS UP

More and more Motion Control products based on PROFINET IRT (Isochronous Real Time) technology are reaching the market. PI member companies such as Danaher, Danfoss, ESR, HMS, Lenze, Mescos, SEW and Siemens are developing PROFINET IRT devices or are offering development services. A

range of products was shown at the recent Hanover Fair and more will be introduced during 2006.

PROFINET is the leading open Ethernet solution for Motion Control applications in automation. It ensures high-performance, real-time communication with unrestricted IT communication in a single network.

PROFINET can synchronize remote, distributed automation systems in real-time by reserving bandwidth for the real-time synchronization of Ethernet switches

by which a stable deterministic communication cycle is set.

The performance of IRT has been proved extensively in prototypes and production machines. ASICs support the technology, and communication modules with IRT functionality are available.

Development kits are also available for rapid implementation of the technology. PROFINET source code stacks for devices and controllers will shortly be available. **Read more about PROFINET for Motion Control here.**

PI News

FIELDBUS INTO LABORATORIES

PROFIBUS International (PI) is the first of the large fieldbus organizations to specify a device profile specifically tailored to the needs of lab devices!

The profile – ‘LabDevices’ – opens the door to seamless integration of labs into PROFIBUS networks, into other automation worlds by means of OPC.

The profile was specified by a PI working group consisting of manufacturers of lab devices and LIM systems, and thematically supported by large users as well as organizations, such as Spectaris and the DIN standards committee.

Following an extensive review phase lasting until the fall of 2006,

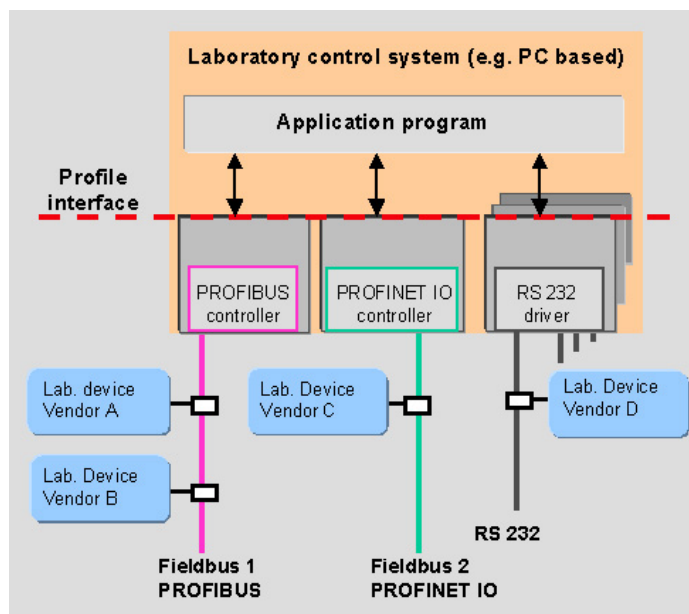

the profile will be available as an official standard for PROFIBUS and subsequently also for PROFINET.

Tightened regulations and quality expectations with simultaneous cost reductions require increased automation of work processes in

industrial and research labs. Standardization areas such as data collection and data communication gains special importance. Today, the field is still very heterogeneous. LIM systems are used for the integrated recording and processing of data,

but there are still no standards for global standardization of processes or data formats.

At the same time, labs and their workflows move ever closer to the actual production processes, with the goal of production monitoring and optimization as direct as possible. This is one more reason why users have a growing interest in seamlessly integrating the data collected in the lab into the dataflow of the entire company, as is done today with production data, thanks to seamless fieldbus technology. In other words, in the future, labs must be moved towards state-of-the-art automation technology such as fieldbuses, OPC and Ethernet, and networked with company data systems. PI is creating the environment for seamless communication through its ‘LabDevices’ profile.

Applications

UK/ WASTE WATER: The introduction of PROFIBUS-enabled IQT valve actuators on a filter bed automation upgrade for Yorkshire Water has facilitated the installation of a highly economical and efficient control network. Stuart Goodwill, M&E Engineer at Mott McDonald Bentley, the partnership design and construction company for the project, said: “Rotork’s PROFIBUS card enabled us to fully exploit the features of PROFIBUS control technology when configuring the design of the network. Employing the analog input fitted as standard on the Rotork card has saved the expense of either installing a separate PROFIBUS interface on all 35 flowmeters or hard-wiring them to the PLC. Instead, the analog signal from each flowmeter is simply linked

to the corresponding actuator for onward communication with the PLC via the PROFIBUS network.”

The automation programme is at Esholt, one of Yorkshire Water’s largest waste water treatment works, serving more than 300,000 homes, and industry. The Rotork IQT actuators are fitted to previously hand-operated plug valves on the secondary treatment percolating filter beds. Constructed over 50 years ago, the plant consists of 70 axial beds and extends over a distance of more than a mile. Effluent arrives from the distribution chamber where it is mixed with reintroduced final effluent to improve consistency before being gravity fed into 35 troughs, each serving a unit of two filter beds. The automation upgrade is designed to improve the flow performance into the beds,

optimize filtration efficiency and prevent damaging problems such as dry bedding and uneven flow distribution that were difficult to avoid when the plant was manually operated.

Electromagnetic flowmeters have been fitted in the pipes serving each trough, adjacent to the Rotork actuated plug valves. The flowmeters and actuators are connected to a new PLC in what is believed to be Yorkshire Water’s first use of a PROFIBUS network on a water treatment plant. Due the sheer size of the filter bed site, the PLC is centrally housed and four separate control buses are used to prevent a reduction in data transmission rates and eliminate repeaters.

The total rate of flow into the plant is divided by 35 and this figure (typically 80 litres/second) is

compared by the PLC to the reading from each flow meter. If the reading is too low or too high the PLC instructs the appropriate Rotork actuator to step the position of the valve until the flow reading is within the operating band.

The actuators also communicate valve position data to the PLC while integral data loggers store operating data including valve movements and torque profiles. All the operating and flow data from the PLC is transmitted via radio modem to the Esholt central SCADA control room. The upgrade was commissioned in 2005 and has improved the treatment of up to 250,000 m³ of effluent per day, helping reach stringent environmental consent targets.

Rotork: +44 1225 733200 or mail@rotork.co.uk or www.rotork.com

New Products

AS-i GATEWAY



A PROFINET to AS-Interface gateway has been introduced by Bihl + Wiedemann. It's believed to be the

first conforming to the new AS-i V3 M4 profile and incorporates advanced diagnostics. It also has an earth fault detector and a noise and over-voltage detector for checking the analog signal. **Bihl + Wiedemann: +49 621 3396 0 or mail@bihl-wiedemann.de or www.bihl-wiedemann.de**

IO-Link STARTER KIT

The IO-Link starter kit from MESCO allows for quick and cost-effective implementation



of masters and slaves. The kit includes all required components for a single node. Due to modular design, individual hardware and software components can be easily customized. Supported are the Physics 2 (three-wire) interface for all baud rates and protocols. The master is equipped such that a fieldbus gateway can be connected through a UART. The master stack also supports USB communication. The documentation offers a detailed description plus an overview of the parameters specified by the standard. **MESCO: +49 7621 89031-42 or info@mesco-systems.com or www.mesco-engineering.com**

CONTROL UNIT

A new Control Unit CU310 PN for Sinamics S120 AC Drives has been launched, specially designed for use with PROFINET in Sinamics S120 single-axis applications. It contains the motion control intelligence for the drive, including positioning functions. PROFINET is now supported by Sinamics S120 in all types of application. **Siemens: www.siemens.de/profinet**



DP-V1 MASTER

Smar's PROFIBUS DP controller DF73 treats discrete and analog signals in a single, integrated and transparent environment for engineering, operation and maintenance. Besides easy connection to PROFIBUS DP slaves such as Variable Speed Drives (VFDs), PROFIBUS PA devices are also connected to the controller, using commercial-of-the-shelf segment couplers. Additionally, the controller accesses conventional signals from a variety of discrete and analog I/O cards. It also has redundant Ethernet ports for High Speed Ethernet connection and a Modbus connection. **Smar: turazzi@smar.com.br**

COPPER TO FIBER CONVERTERS



ODW-611 and ODW-612 convert between standard PROFIBUS DP copper cables

and a fiber optical link to extend network lengths in harsh industrial applications up to 80 km. ODW-611 is suitable for point-to-point installations, whilst the ODW-612 can be used in either redundant ring or multi-drop applications. In a redundant ring the overall distance can be hundreds of miles. The converters have a status interface for error indication and as LED error indication. A redundant power supply is also available.

Westermo: sales@westermo.co.uk or 01489 580585 or www.westermo.co.uk

HIGH SPEED WIRELESS



Connect PROFIBUS field devices 'over-the-air' and up to 20 miles away, using these new

ProLinX Wireless Gateways. Progressive technology provides unprecedented flexibility, allowing heterogeneous networks to share process and status data wirelessly. Using the ProSoft Wireless Protocol (PWP), data is transferred securely and efficiently between different industrial networks and protocols in a high-performance way. **ProSoft Technology: www.prosoft-technology.com**

Applications



AUSTRALIA/ OPEN CAST MINING:

Draglines scoop up overburden and typically swing it around a 100-degree arc before dumping the load and returning. The swing cycle is around 60 seconds and during this period, power profile can range from 9 MW to 40 MW.

Managing this process requires large and complex DC relay logic, and at most sites the electrical setup has remained unchanged over decades. However, since the mid-nineties, many of the draglines in Australia have been undergoing major overhauls and upgrades, presenting the opportunity to implement more advanced automation, protection and control systems.

Recognising this, a coal mining company in Central Queensland, BMACO, undertook a trial in 2002, to implement a PROFIBUS network on a machine to assess its viability in the harsh dragline working environment.

"Since this trial was the first such known installation in the world, we built-in full hard-wired redundancy," explains Andrew Guilbert, Manager Electrical Engineer, INETE P/L.

The network used a GE Fanuc IC693CPU363 PLC CPU with five Siemens DC Simoreg Drives and a Siemens AC Masterdrive. It was initially commissioned at 500 kbps, and once proven was set to run at 12 Mbps. "The trial was a huge success and PROFIBUS has now been adopted as a standard for communications between the controlling PLCs and the motion drives," says Guilbert. "The redundancy has been stripped out, effectively making PROFIBUS the life blood of the system."

The upgrade has freed up space in the switch rooms. It also provides simplicity in modifying control and enhancing automation and enunciation of the dragline. The robustness and speed of PROFIBUS has resulted in it being implemented on seven more draglines. Another four machines will adopt the technology this year and several others will follow suit. More from: **a.guilbert@ine-tech.com or + 1300 363 707 or here**

COMPACT I/O



The new IM 151-1 COMPACT interface module comprises a terminal

module and an electronic module and is available in two versions: Purely digital input module 32DI or Digital mixed module 16DI/16DO. The block contains 32 channels and can be expanded with fine modularity up to 80 channels (analog and digital mixed) or a maximum of 12 modules. The station is expanded simply and quickly by means of the integral backplane bus. In the event of a fault, load groups can be shut down individually and selectively on the block. **Siemens: www.siemens.com/et200s**

DEMO DTM CD

A 90 day free CD demo is available of the Device Management Tool DSV401 (SMART VISION) based on FDT/DTM.



DSV401 (SMART VISION) is a central tool with project management services, fieldbus drivers, elementary bus diagnosis and event logging. It can be used for configuration, parameter setting, calibration, commissioning, diagnosis and maintenance. 30 DTMs/DMAs are available on the CD for more than 220 ABB field devices! All ABB HART and PROFIBUS DTMs are certified by the FDT Group. **ABB: +49 6023 92 3129 or bernd.hassenpflug@de.abb.com**

PI World

MIDDLE EAST



A PI meeting at Hannover Fair in April introduced a new face to the PI community. Preggs Naidoo, based in the United Arab Emirates,

explained to the

meeting how he plans to establish a new RPA and Competence Center in the Middle East region. Preggs later wrote thanking everyone for their time and the knowledge shared during his week in Germany. He plans a series of events and hopes that other RPA personnel can participate to give him an early boost in this critical market. 'Good luck' Preggs from all of here at PROFINEWS and please keep us informed about your activities.

Contact Preggs at: **+971 4 366 0180** or middle.east@profibus.com

NETHERLANDS



PROFIBUS will be at Aquatech Amsterdam 2006, 26 - 29 September 2006 to present the wide range of PROFIBUS

solutions that enhance and optimize water processes. Presentations about Life Cycle Costs, Asset Management and Case Studies will be given.

Aquatech has also set up 'Aquastages' where exhibitors and independent organisations can present latest technology and innovations. www.nl.profibus.com or www.aquatechtrade.com.

PROCENTEC, the PROFIBUS Competence Center, is now officially accredited as a PROFINET Competence Center (picture below). Services like troubleshooting, audits, consultancy and training are provided. Primary experts include Paulo Silva, Mark de Brabander and Patrick van Marrewijk. Initial training and demo equipment has been donated by Siemens and Phoenix Contact.



CHINA

In May 2006, PROFIBUS Roadshows were held in Beijing and Xi'an. Over 450 people from the petrochemical and regular process industries participated and saw practical presentations about the technology basics, design, commissioning, wiring and installation. During breaks the participants visited a product exposition of the organizing companies (Endress+Hauser, Siemens, Weidmuller, M-Systems, PROCENTEC, Woodhead, Huakong, DS System). At the end a panel discussion was conducted where the audience took advantage of the professional know-how of the presenters, who were addressed with technical issues concerning their applications. The enthusiastic audience was deeply impressed by Mr. Dennis



van Booma (left) from PROCENTEC in the Netherlands and other presenters, who were bombarded with more than 100 questions about cabling, grounding, EMC and testing. The conclusion from Mr. Lee (chairman of CPO) and Mr. Tang (director of CPPC) was that detailed information about cabling and installation is a 'must'. CPO will organize training on all aspects of PROFIBUS applications, which will enhance the knowledge of Chinese end-users.



JAPAN

PROFIBUS and PROFINET will be presented during Japan PROFIBUS Organization's PROFIBUS Days on July 4th, 7th and 10th. The invitation flyer (pictured) can be **downloaded here**. JPO has also translated the ARC White Paper called 'PROFINET: an all-encompassing Industrial Ethernet Solution'. The translated version can be **downloaded here**.



ITALY



INN.TEC S.r.l., a PROFIBUS Competence Center since 2004, is now also a PROFINET Competence Center. PROFILAB, the PROFIBUS laboratory of INN.TEC, is run jointly with the Department of Electronics for Automation at the University of Brescia, which carries out intense experimental activity focused on real-time applications. PROFIBUS and PROFINET Competence Center Italy offer comprehensive educational, development and support services for PI technologies. Their most recent event was the 'Hands-on PROFIBUS & PROFINET' one-day course organized in March in conjunction with

SWITZERLAND

PROFIBUS Switzerland is organizing an 'industrial networks forum' on June 22, 2006 in Zürich, along the lines of their 'focus.technology forum 2006'. It features 8 lectures focused on the practical benefits for end users, including topics such as automation of a plant with PROFINET, the benefits of safety bus systems and PROFINET in process automation. The connection of maintenance data between field and MES with PROFINET is also to be covered, along with PROFIsafe and the PROFIdrive motion-control interface of PROFINET.

PNI (RPA Italy). Delegates from more than 10 companies attended classes held by Dr. P. Ferrari and Ing. F. Venturini. During the same month a PROFINET Day was held in Milan, organized by PNI in conjunction with the PROFIBUS Nutzer Organization (PNO) Germany, which was attended by 70 delegates. The event concentrated on the development concepts of PROFINET. First, the status of the harmonization and enhancements achieved to date were explained, followed by an overview of future developments. Three user presentations demonstrated how PROFIBUS and PROFINET are used in real applications and products. Participants showed great interest in everything and the closing discussions helped clarify many technical aspects of PROFINET.

PI Network

Australia - Mr. John Immelman
Tel.: +61 3 9761 5599; Fax: +61 3 9761 5525
Email: australia@profibus.com
www.aus.profibus.com

Belgium - Mr. Herman Looghe
Tel.: +32 2 706 80 00; Fax: +32 2 706 80 09
Email: belgium@profibus.com
www.be.profibus.com

Brazil - Mr. Paulo Camargo
Tel.: +55 11 3833 4958; Fax: +55 11 3833 4183
Email: brazil@profibus.com
www.br.profibus.com

China - Mrs. Wang Jun
Tel.: +86 10 62 02 92 18; Fax: +86 10 62 01 78 73
Email: china@profibus.com
www.cn.profibus.com

Czech Republic - Mr. Zdenek Hanzalek
Tel.: +420 2 2435 7610; Fax: +420 2 2435 7610
Email: czechrepublic@profibus.com
www.cz.profibus.com

Denmark - Mr. Kim Husmer
Tel.: +45 40 78 96 36; Fax: +45 44 07 77 36
Email: denmark@profibus.com
www.dk.profibus.com

Finland - Mr. Taisto Kajanen
Tel.: +35 8 9 5307259; Fax: +35 8 9 5307360
Email: finland@profibus.com
www.sf.profibus.com

France - Mrs. Christiane Bigot
Tel.: +33 1 45 74 63 22; Fax: +33 1 45 74 03 33
Email: france@profibus.com
www.fr.profibus.com

Germany - Mr. Peter Wenzel/Mr. Volker Oestreich
Tel.: +49 721 96 58590; Fax: +49 721 96 58589
Email: germany@profibus.com
www.de.profibus.com

Ireland - Mr. Hassan Kaghzchi
Tel.: +353 61 202 107; Fax: +353 61 202 582
Email: ireland@profibus.com
www.ir.profibus.com

Italy - Mr. Maurizio Ghizzoni
Tel.: +39 030 3384030; Fax: +39 030 3396999
Email: pni@profibus.com
www.it.profibus.com

Japan - Mr. Shinichi Motoyoshi
Tel.: +81 3 54 23 86 28; Fax: +81 3 54 23 87 34
Email: japan@profibus.com
www.jp.profibus.com

Korea - Mr. Cha Young Sik
Tel.: +82 2 523 5143; Fax: +82 2 523 5149
Email: korea@profibus.com
www.rk.profibus.com

Netherlands - Mr. Dolf van Eendenburg
Tel.: +31 33 469 0507; Fax: +31 33 461 6638
Email: netherlands@profibus.com
www.nl.profibus.com

Norway - Mr. Ivar Sorlie
Tel.: +47 2272 8972; Fax: +47 904 05509
Email: norway@profibus.com
www.no.profibus.com

Poland - Mr. Dariusz Germanek
Tel.: +48 32 371365; Fax: +48 32 372680
Email: poland@profibus.com
www.profibus.com

Russia - Mrs. Olga Sinenko
Tel.: +7 095 742 68 28; Fax: +7 095 742 68 29
Email: russia@profibus.com
www.rus.profibus.com

Slovakia - Mr. Richard Balogh
Tel.: +421 7 6029 1411; Fax: +421 2 6542 9051
Email: slovakia@profibus.com
www.sk.profibus.com

South-East Asia - Mr. Volker Schulz
Tel.: +65 6490 6464; Fax: +65 6490 6465
Email: southeastasia@profibus.com
www.sea.profibus.com

Southern Africa - Mr. Dieter Dierchert
Tel.: +27 11 201 3200; Fax: +27 11 609 5950
Email: southernafrica@profibus.com
www.rsa.profibus.com

Sweden - Mr. Peter Bengtsson
Tel.: +46 4 51 49 460; Fax: +46 4 51 89 833
Email: sweden@profibus.com
www.se.profibus.com

Switzerland - Ms. Karin Beyeler
Tel.: +41 32 672 03 25; Fax: +41 32 672 03 26
Email: switzerland@profibus.com
www.ch.profibus.com

UK - Mr. Bob Squirrel
Tel.: +44 20 7871 7413; Fax: +44 870 141 7378
Email: uk@profibus.com
www.uk.profibus.com

USA & CANADA - Mr. Michael Bryant
Tel.: +1 480 483 2456; Fax: +1 480 483 7202
Email: usa@profibus.com
www.us.profibus.com

Addresses of PI Competence Centers and Test Labs can be found at www.profibus.com and www.profinet.com

Editor: Geoff Hodgkinson
1 West St. Titchfield, Hants, UK PO14 4DH.
Tel.: +44 (0) 1329 846166; Fax: +44 (0) 1329 512063
geoff@ggh.co.uk

Published by: PNO
Haid-und-Neu-Str. 7
D-76131 Karlsruhe, Germany