

Device Integration

G S D

E D D

F D T



Device Integration in Field Bus Technology

Device Integration in Field Bus Technology

Field bus technology provides the full range of user benefits through consequent "openness" which is equivalent to the utilization of devices from many different manufacturers in one system. An average installation embraces over 100 field device types from 10 or more different manufacturers with at least 10 different operating programs.

This inevitably results in considerably more time and effort required for installation, version management, and device operation.

To simplify these processes, PROFIBUS has developed the standards for the central and uniform operation of field devices.



Device integration is synonymous with making the information and functions of field devices centrally accessible for various tasks in the life cycle of a system

- during the engineering process for configuration and parameter assignment,
- during plant operation for monitoring, alarms and asset management (diagnosis, maintenance).

Device integration is normally carried out by mapping the functions of the device in the operating software (operating tool). This is optimized through consistent data maintenance over the life cycle of the system with identical data structures for all devices.

General Station Data (GSD)

The GSD is the obligatory "ID card" for each and every PROFIBUS device. It contains the key data of the device, details relating to its communication capabilities and other information relating, for example, to diagnosis values.

In the device integration process the GSD is sufficient to employ for the cyclic exchange of measurement values and manipulated variables between the field device and the automation system.

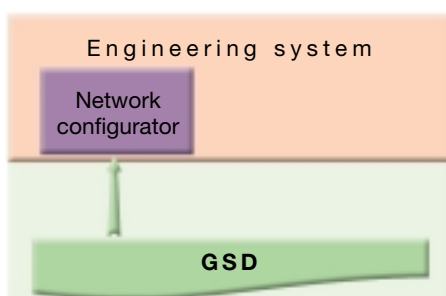

GSD is

- an electronic data sheet that is provided by the manufacturer of the device,
- a simple textual description of the device features for PROFIBUS communication,
- the basic description for each PROFIBUS device that is to be integrated into the engineering system for the purpose of configuring the PROFIBUS network to allow cyclic communication with the PROFIBUS master.

Solutions for Device Integration with PROFIBUS

PROFIBUS is working intensively on the issue of device integration and attaches equal importance to the two aspects "standardization and flexibility" and "benefits for users and manufacturers". The result is really convincing: with its GSD, EDD and FDT/DTM concept, PROFIBUS offers future-oriented integration technology for the operation of devices that display different levels of complexity.

Wide application base

PROFIBUS is the only field bus system worldwide that - thanks to its modular design - is equally suited to all applications in the area of automation technology,

- from production to process automation,
- in standard and safety-oriented installations,
- from simple to complex solutions.

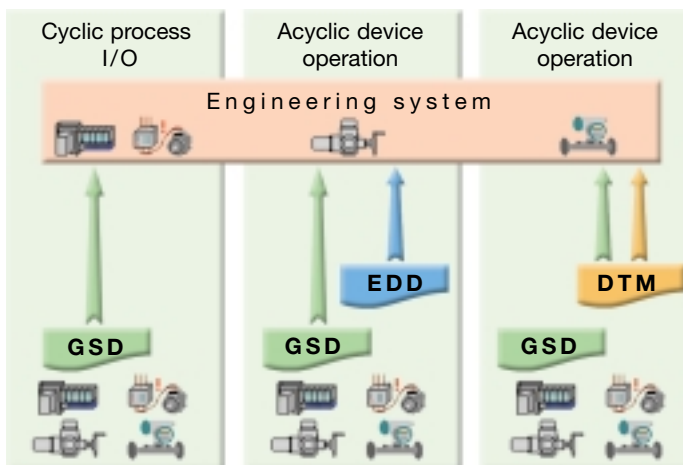

Structured Integration Technologies

With a view to its wide application base, PROFIBUS provides three different technologies for device integration all of which

- guarantee the centralized and uniform operation of devices,
- take into consideration the specific requirements of the individual sectors such as motion control or process engineering,
- are structured with regard to their features and scope of performance and
- offer plant operators and device manufacturers a high level of openness allowing them to select the optimal solution for their respective applications.

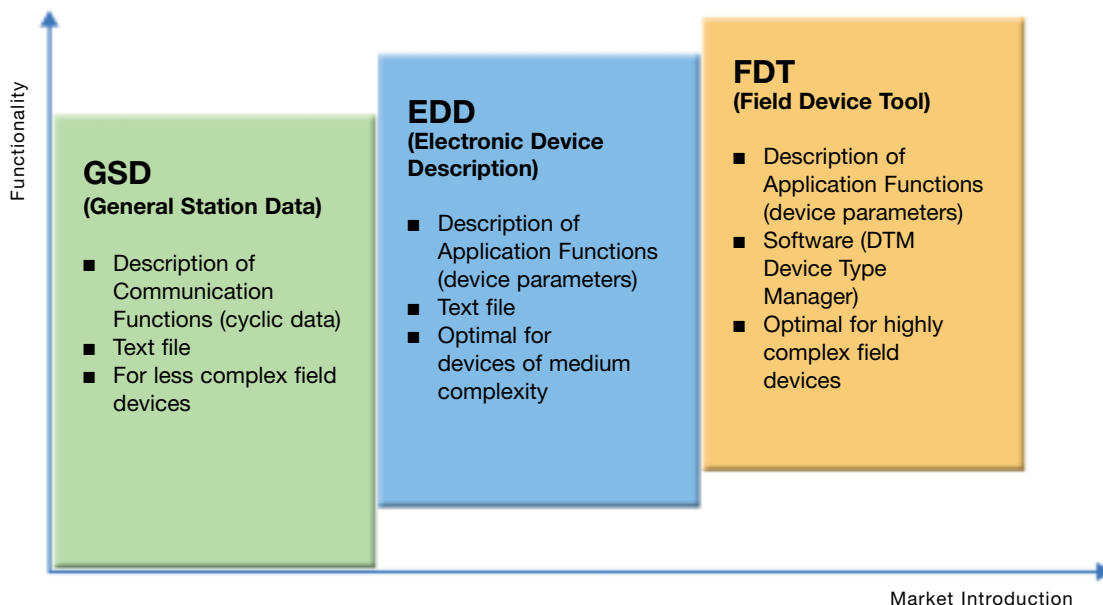

Electronic Device Description (EDD)

GSD is not sufficient to describe the user-related functions and parameters of field devices of higher complexity. The configuration, parameterization, commissioning, maintenance and diagnosis of the devices from the engineering system requires a

more efficient language. To meet this requirement PROFIBUS further developed the Electronic Device Description Language (EDDL) which was standardized in IEC 61804-2 and is used to create EDDs.

An EDD is

- a textual device description that is not dependent on the operating system of the engineering system,
- the description of the device functions that are communicated acyclically including graphical options as well as device information such as a order data, materials and maintenance messages etc.,
- a file that is developed and provided by the manufacturer of the device and used in conjunction with GSD,
- the basis for processing and display using an EDD interpreter.

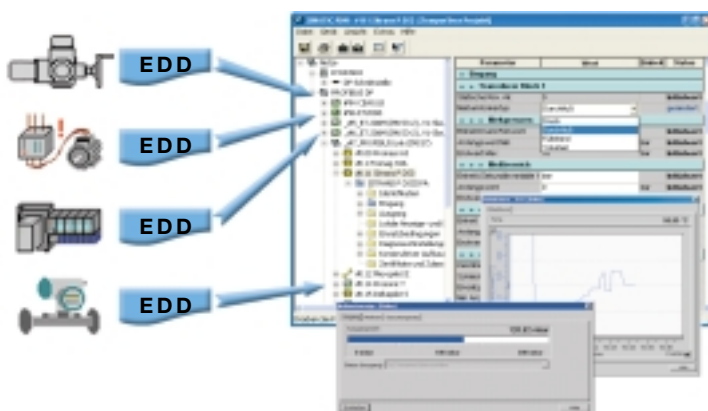
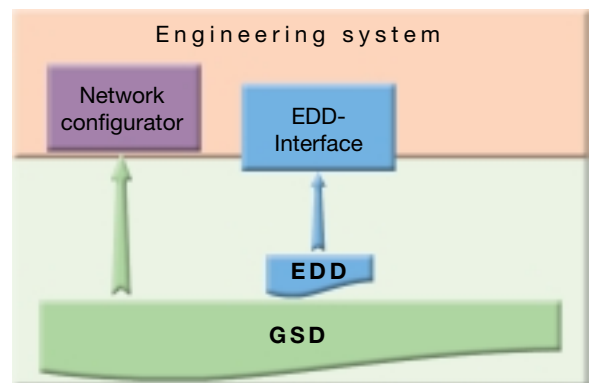

The EDD interpreter

- is an open interface between the EDDs and the operating program,
- provides the visualization data for the operating program with a uniform Look&Feel across all devices and manufacturers,
- can be used as part of an independent operating program or engineering system.

Features of EDD technology

- Independent of engineering and control systems and therefore facilitates the decoupling of the life cycles of the plant, control system, operating system and field devices
- Routing through various networks by means of PROFIBUS standards
- Large installed base (with over 1,000 devices from more than 100 manufacturers)
- Standardized version management as well as value comparison and device replacement with data transfer
- Particularly suitable for devices with standardized functions
- Cost-effective and fast development

Field Device Tool (FDT) Interface and Device Type Manager (DTM)

In contrast to the description-based technologies GSD and EDD, FDT/DTM technology is a software-based device integration method. The DTM is a software component and communicates with the engineering system via the FDT interface.

With FDT/DTM, the flexibility and degrees of freedom of software programs can be used for device integration over the entire life cycle of a system.

A DTM

- is a device-operating program that paves the way for the utilization of the device functions (Device-DTM) or the communication capabilities (Communication-DTM);
- has a standardized FDT interface (Field Device Tool) to a peripheral application (Engineering System),
- can, in a similar way as a printer driver, be run on all FDT peripheral applications,
- is programmed by the manufacturer specifically for the device or generated automatically,
- contains a user interface that is optimized for each device and
- also provides GSD information.

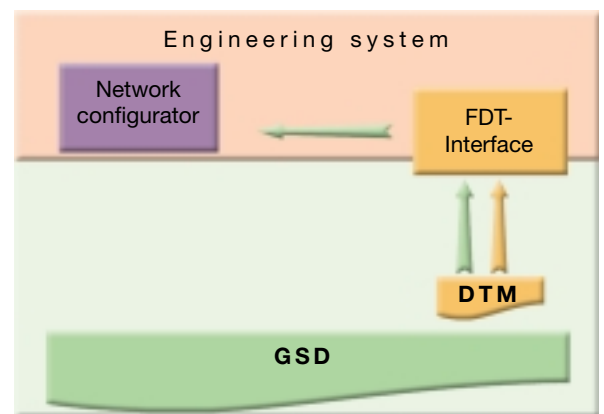

The FDT interface

- is an open, vendor-neutral interface specification (and not a "tool" as the name suggests),
- facilitates the open integration of field devices from different manufacturers into operating programs using DTMs,
- defines the interaction between the DTMs and an FDT peripheral application in the operating tool or engineering system.

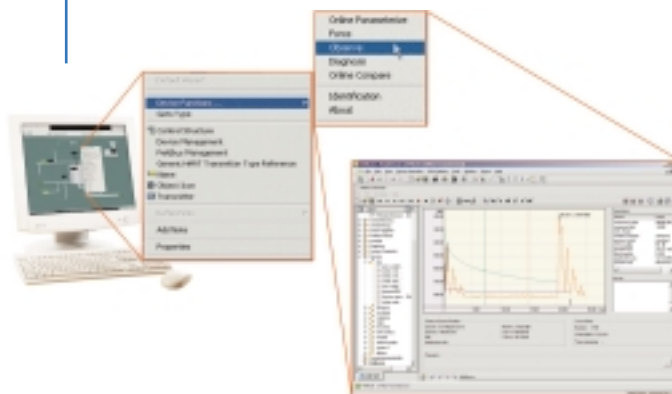

Features of FDT/DTM technology

- High level of flexibility in terms of program layout and easy implementation of unique features
- Utilization of all of the device's functions
- Utilization of existing and, if applicable, certified programs is possible
- Responsibility for device and DTM lies in one hand (important for safety-relevant applications)
- Manufacturer-independent routing through various networks
- Option of an optimized user interface that is realized by the manufacturer of the device
- Suitable for the support of high device innovation cycles or graphic and interactive functions
- Adoption of the automatic version management of the field devices



Numerous User Benefits

There are significant reasons to explain the leading position that PROFIBUS has established in the world market. Right from the very beginning, all developments at PROFIBUS successfully combined standardization with versatility allowing the application base to be extended to all areas of industry. As a result, users can avail themselves of uniform solutions that

guarantee system-wide consistency and long-term investment protection. The optimal structure of the three methods of device integration guarantees users and manufacturers a high level of planning and organizational freedom. The benefits that can be derived from having direct access to device intelligence, from central device management and standardization are common to all three methods.

